

RF FRONT END

T1= 2t Pri, Sec 12t
38swg
en Cu on CB IF can

L1= Same as T1, no
Primary winding

T2=3t Pri, Sec 24t
38swg
En Cu CB IF can

L2= Same as T2,no
Primary winding

T3= 3t Pri, Sec 27t
38swg en Cu on CB
IF can

L3= Same as T3,
no Primary winding

All diodes 1N4148
All fets BF961 etc.
Resistors in Ohms

T4= 10t bifilar
30swg en Cu on
FT37-43

T5= 14t Pri, 4t sec
30swg en Cu on
FT37-43

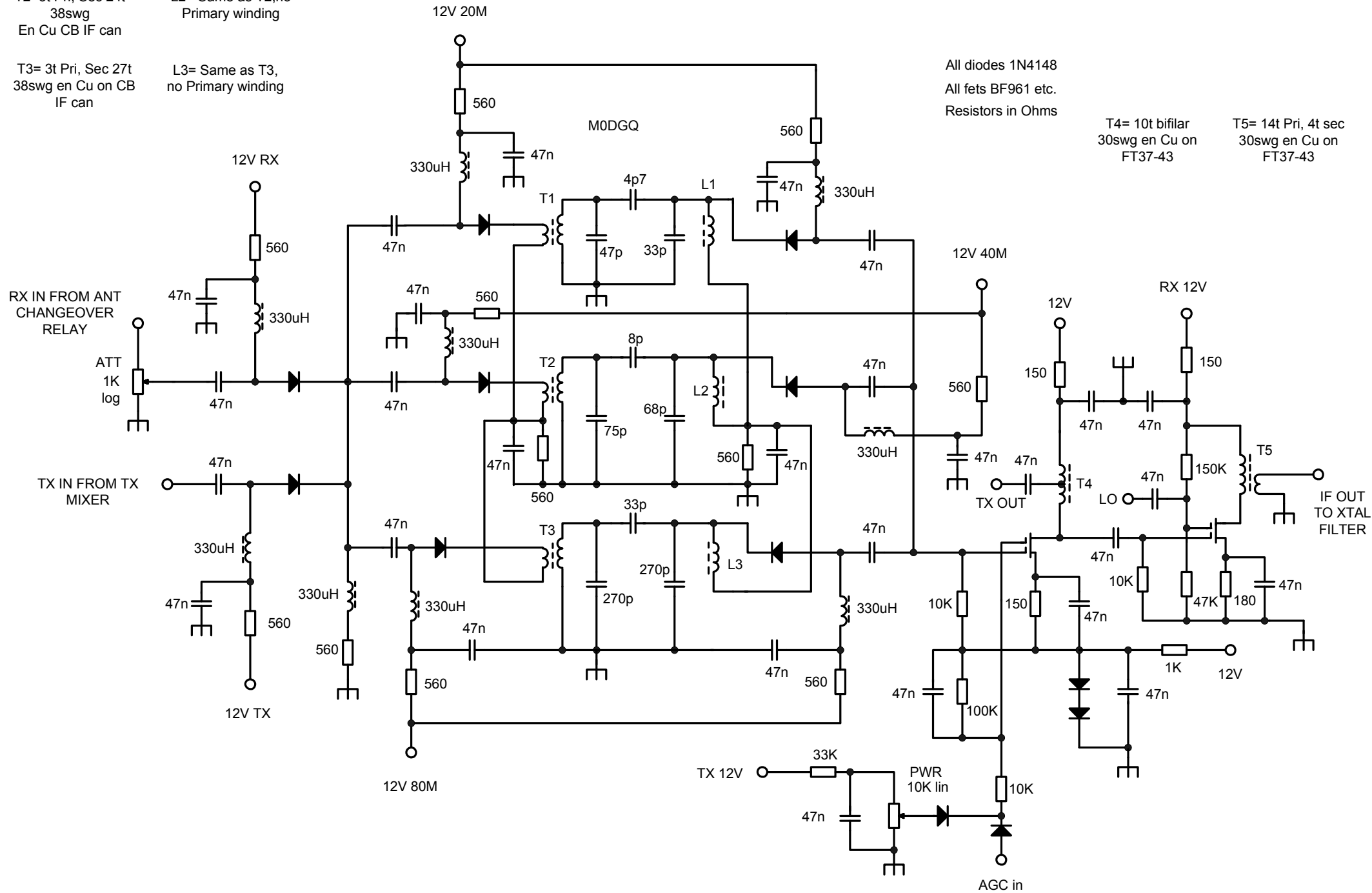

IF OUT TO XTAL FILTER

AGC in